

GRAPHITE GASKET TYPE FULL FACE DIN 2576 - PN10

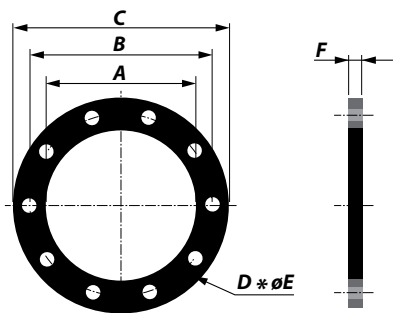

Article No.	Size (Inch)	NB (mm)	Pipe (mm)	A (mm)	B (mm)	C (mm)	D Number of holes	E Diameter of holes (mm)	F (mm)	Weight (kg)
213110020010	1	25	33.4	35	85	115	4	14	2	0.1
213110020013	1.25	32	42.2	43	100	140	4	18	2	0.1
213110020015	1.5	40	48.3	49	110	150	4	18	2	0.1
213110020020	2	50	60.3	61	125	165	4	18	2	0.1
213110020025	2.5	65	76.1	73	145	185	4	18	2	0.2
213110020030	3	80	88.9	90	160	200	4	18	2	0.2
213110020040	4	100	114.3	116	180	220	4	18	2	0.2
213110020050	5	125	139.7	142	210	250	8	18	2	0.2
213110020060	6	150	168.3	171	240	285	8	22	2	0.3
213110020080	8	200	219.1	222	295	340	8	22	2	0.3
213110020100	10	250	273.0	276	350	395	12	22	2	0.3
213110020120	12	300	323.9	327	400	445	12	22	2	0.3
213110020140	14	350	355.6	360	460	505	12	22	2	0.4
213110020160	16	400	406.4	411	515	565	16	26	2	0.4
213110020180	18	450	457.2	461	565	615	16	26	2	0.4
213110020200	20	500	508.0	512	620	670	20	26	2	0.5
213110020240	24	600	609.6	614	725	780	20	30	2	0.8
213110020280	28	700	711.2	716	840	895	24	30	2	0.8
213110020320	32	800	812.8	818	950	1015	24	33	2	0.8
213110020360	36	900	914.4	920	1050	1115	24	33	2	1
213110020400	40	1000	1016.0	1022	1160	1230	28	36	2	1

CHARACTERISTICS

Gaskets Hole pattern according type DIN 2576 - PN10

Material Gaskets are produced out of graphite

Range Diameter range from 33.4 mm up to 1016 mm

Thickness 2 mm, with an option for 3 and 4 mm

Temperature The maximum allowable temperature is 600°C